

Ultimate Trilennium® Astragal Cut Down Instructions



8817 West Market Street
Colfax, NC 27235 | 800.334.2006
www.enduraproducts.com

Tools Required:

- Pencil/Marker
- Tape Measure
- Chop Saw

Optional Parts:



Tail Cap

Important Notes:

- All cuts should be from the **top of the astragal**.
- If the trim strip is present, remove from the astragal body.
- The **maximum cut down length** for the Ultimate Trilennium Astragal is dependent upon the handle height of the lock:
 - For **6/8 Astragals**, the minimum length of the astragal is the handle height + 38".
 - For **7/0 Astragals**, the minimum length of the astragal is the handle height + 38" OR a total length of 74" - whichever is greater.
 - For **8/0 Astragals**, the minimum length of the astragal is the handle height + 48-3/8" OR a total length of 86" - whichever is greater.
- Example: For a 6/8 Astragal with a handle height of 36", the minimum astragal length would be 74" (36" + 38" = 74")

STEP 1: INITIAL PREPARATION

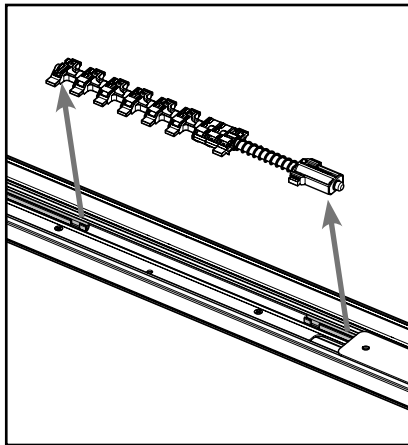

a. Remove the spine assembly from the upper half of the astragal body. Set aside for reinstallation.

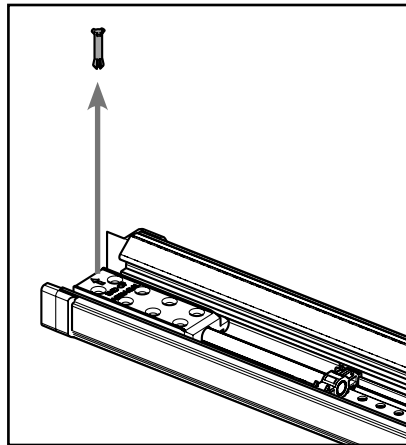

b. Remove the orange securing pin from the upper bolt.

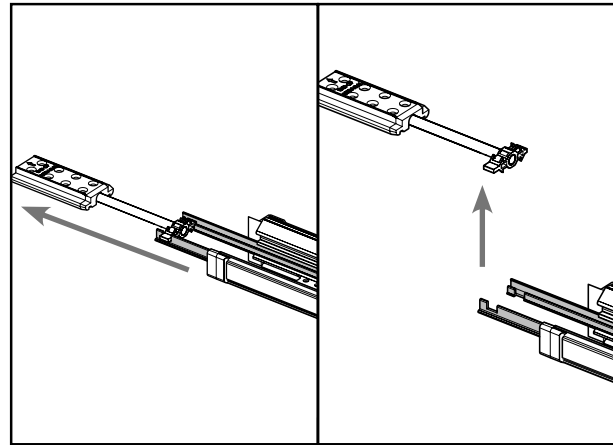

c. Slide the drive rods out of the astragal body and lift the upper bolt out of the astragal. Slide the drive rods back into the astragal body.

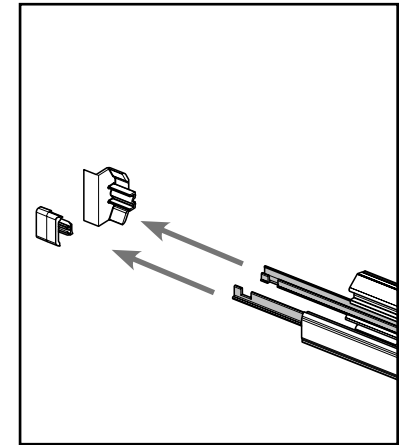

d. Remove the upper trim cap, and tail cap if present, from the astragal body.

Rev. Date: 3/18/2024
©2017 Endura Products, Inc.

Innovation protected under patents and patents pending in U.S. and Canada. See www.EnduraPatents.com.

STEP 2: CUT ASTRAGAL TO SIZE

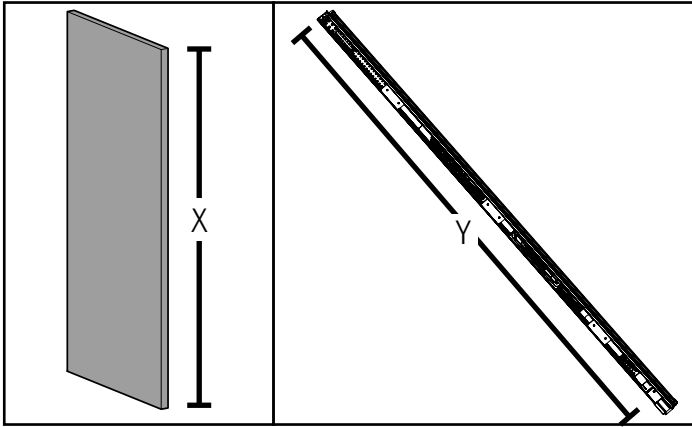

a. Measure the length of the door panel (X) and the length of the astragal (Y) on the **narrow edge**.

b. Round the length of the door panel (X) and the length of the astragal (Y) down to the closest half inch. Subtract the rounded length of the door panel from the rounded length of the astragal to determine your **index number**.

Example:

To determine index number:

- If the astragal length is 79-1/4", round it down to **79"**.
- If the length of the door panel is 75-3/4", round it down to **75-1/2"**.
- $79" - 75-1/2" = 3-1/2$ is the index number.

IF YOU **DO** HAVE A TAIL CAP AVAILABLE:

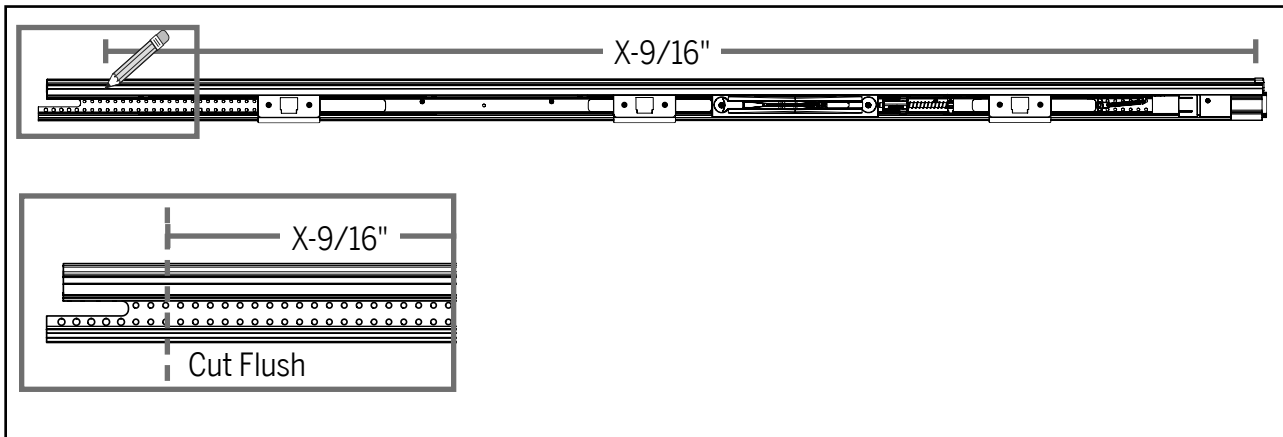

a. Starting at the **bottom** of the astragal and measuring along the **wide side**, measure and mark (X- 9/16"). Cut the astragal flush at this location.

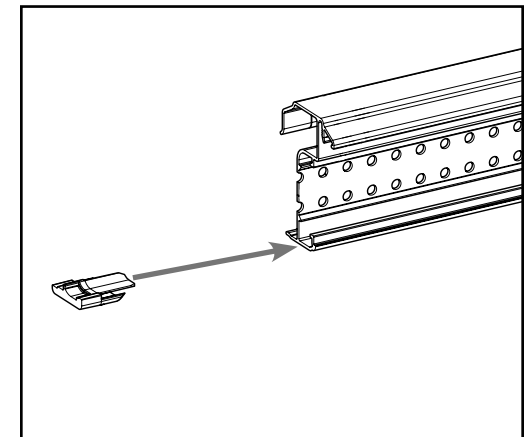

b. Insert the tail cap onto the **narrow side** of the astragal body.



If drive rods are in the way of the cut down, slide further into the astragal or remove temporarily to avoid damage to them.

STEP 2 (CONT.): CUT ASTRAGAL TO SIZE

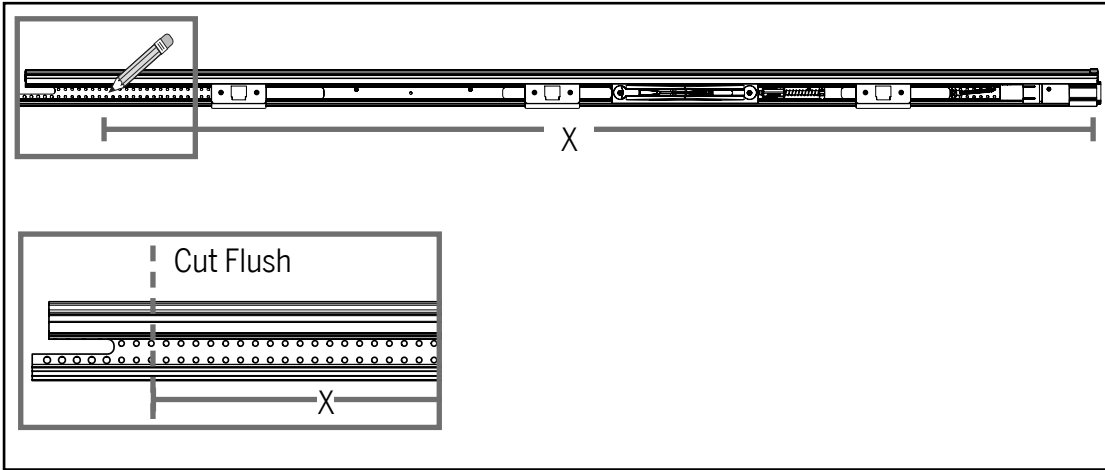

a. Starting at the **bottom** of the astragal and measuring along the **narrow side**, measure and mark (X) on the astragal. Cut the astragal flush at this location.



If drive rods are in the way of the cut down, slide further into the astragal or remove temporarily to avoid damage to them.

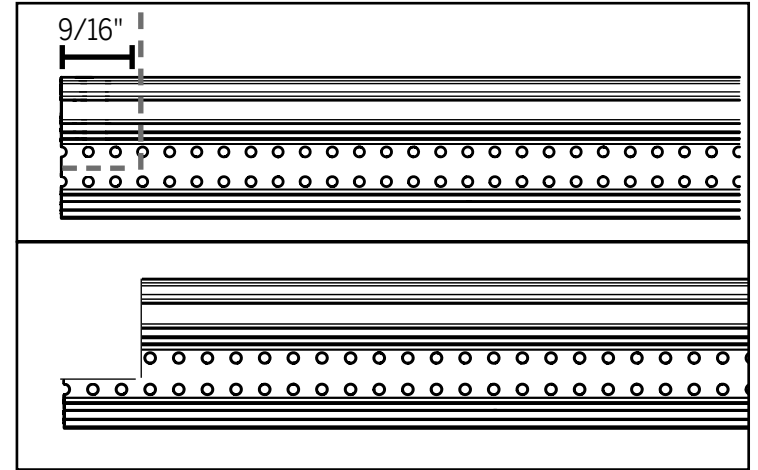

b. To renotch the astragal measure 9/16" from the cut end of the astragal. Using a chop saw, cut at this point, until the space between the rows of holes in the astragal body. **Do not cut it flush.**

STEP 3: REINSTALL UPPER BOLT

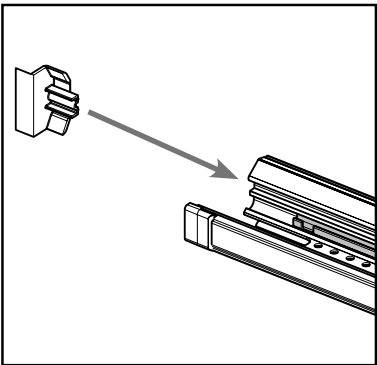

a. Reinstall the upper trim cap.

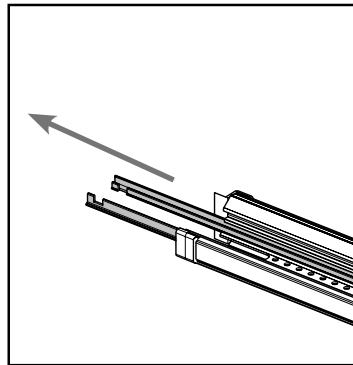

b. Slide the drive rods out to expose the notches.

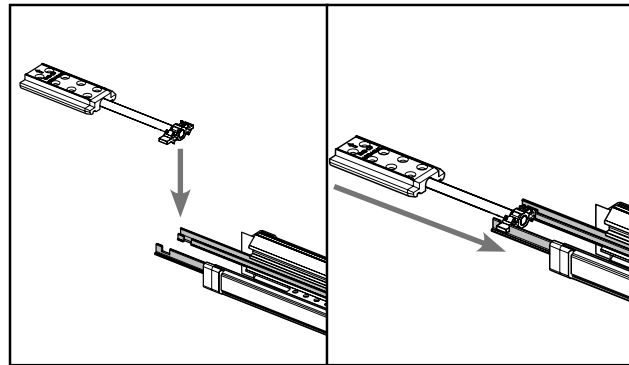

c. Replace the upper bolt into the notches on the driver rod and slide the bolt back into the astragal body so the end of the bolt sleeve is flush with the end of the astragal.

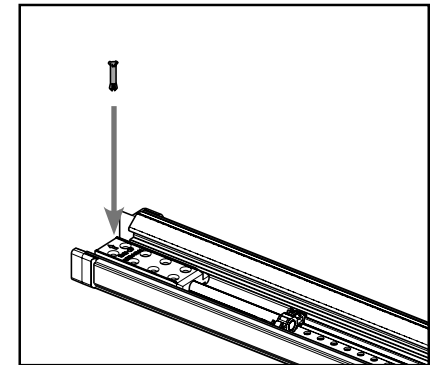

d. Replace the orange securing pin into the hole in the bolt sleeve that aligns with the holes in the astragal body.

STEP 4: RESIZE AND REINSTALL SPINE ASSEMBLY

a. Before replacing the spine assembly, adjust the length using index number from Step 2.

Example: If index number is **3-1/2"**, to appropriately resize the spine assembly, remove one 1/2" spacer and three 1" spacers.

ADJUST 1" INCREMENTS

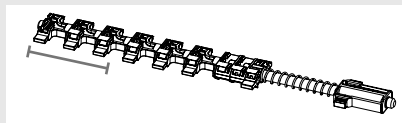

Identify the number of 1" segments needing to be removed.

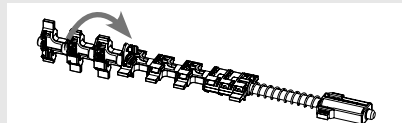

Rotate the identified segments 90° to unlock them from the spine.

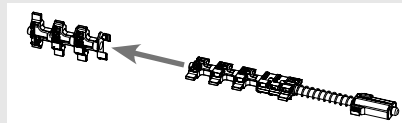

Pull the rotated segments off of the spine and discard.



ADJUST 1/2" INCREMENTS

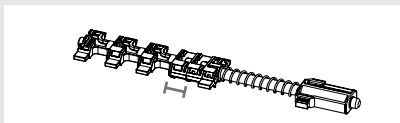

Identify the number of 1/2" segments needing to be removed.

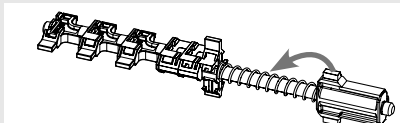

Rotate the spine head and first segment to unlock them from the spine.

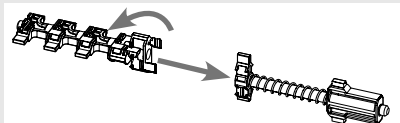

Remove the spine head and first segment and set aside. Rotate the segments needing to be removed.

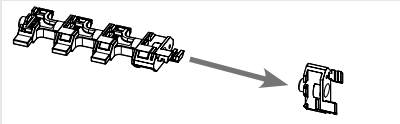

Pull the rotated segment off of the spine and discard.

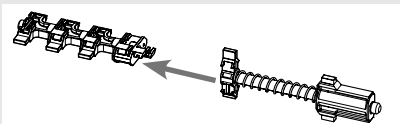

Keeping the spine head rotated, reconnect it to the remaining segments and rotate it back to snap into place.

b. Install the resized spine assembly into the astragal body, keeping the long tabs of the spine segments aligned with each other on the **narrow side** of the astragal.

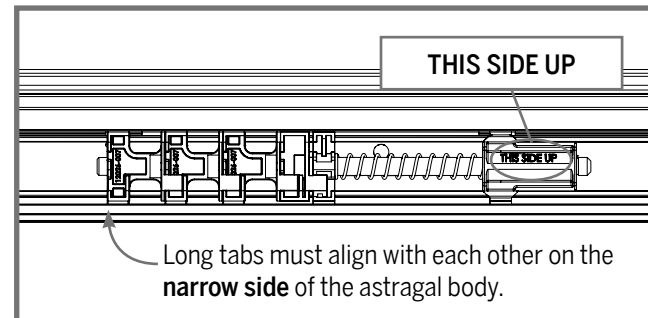
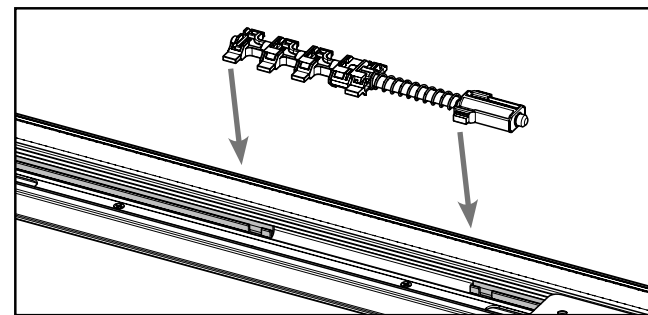

STEP 5: CONFIRM FLIP LEVER OPERATION

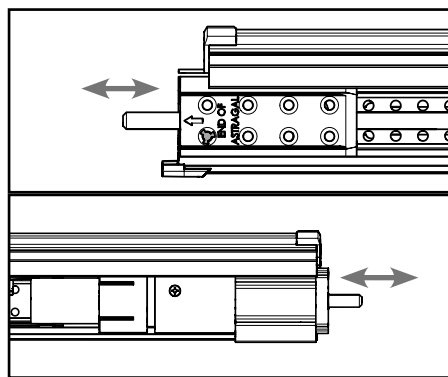
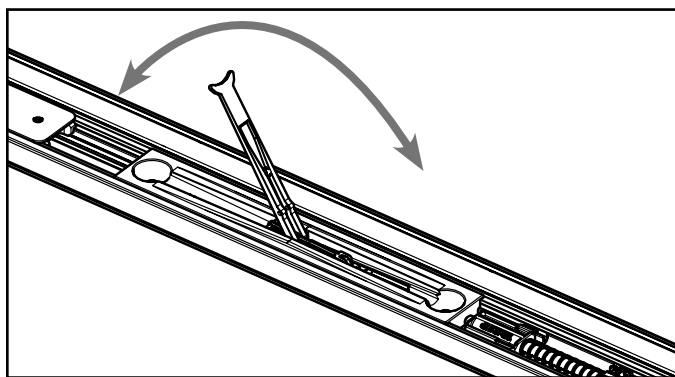

Engage the flip lever assembly and ensure both the upper and lower bolts move out smoothly.