

# Ultimate PanoLock®+Astragal

## Outswing Field Installation Instructions



8817 West Market Street  
Colfax, NC 27235 | 800.334.2006  
www.enduraproducts.com

### Tools Required:

- Pencil/Marker
- Utility Knife
- Drill (3/8" and 5/8" Bits)

### Kit Includes:

- (2) Strike Plates
- (4) #8 x 3" Screws

## STEP 1: INSTALL HEADER AND SILL BOLT RECEIVERS

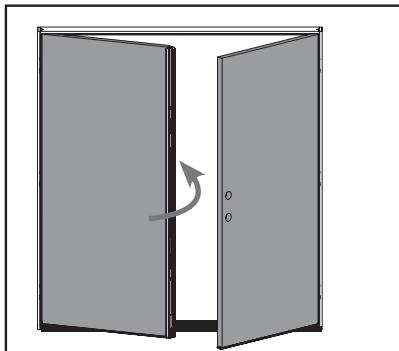

a. Close the inactive door panel until the weatherstrip on the header is compressed.

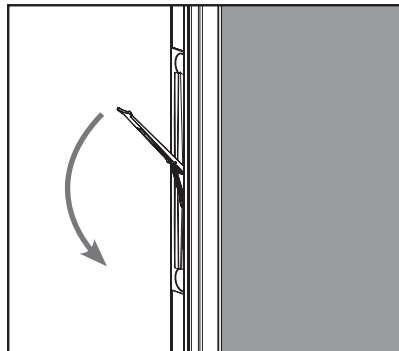

b. Engage the flip lever so the upper and lower bolt pins come in contact with the header and the sill. Mark these points of contact.

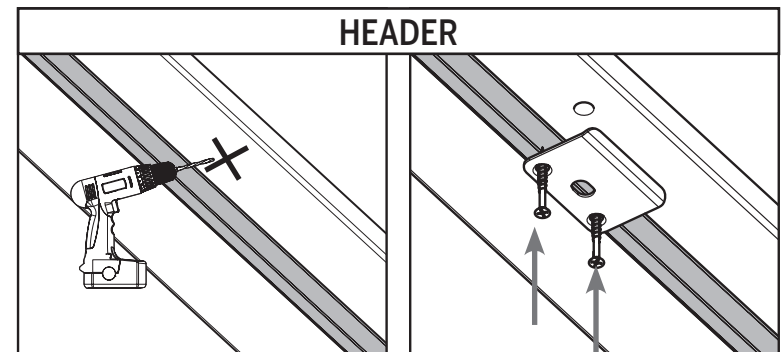
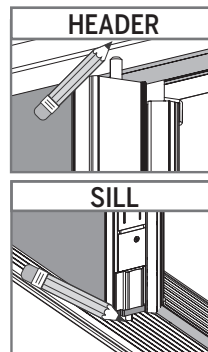

c. At the marked location on the header, drill a hole **3/8" in diameter** and at least **1-3/8" deep**. Install one of the strike plates into the header, using two #8 x 3" screws.

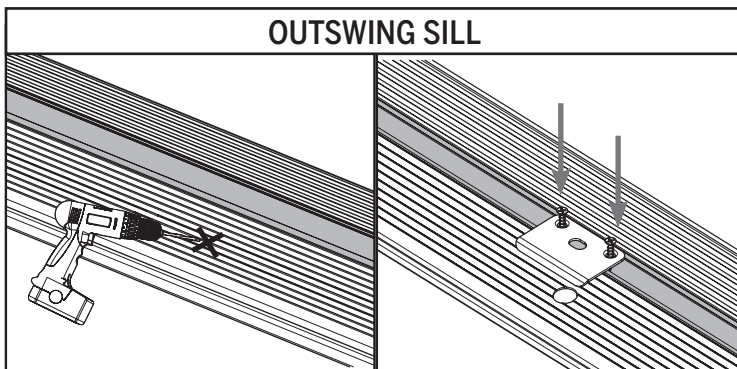

d. At the marked location on the sill, drill a hole **5/8" in diameter** and at least **1-3/8" deep**. Install the other strike plate into the sill, using two #8 x 3" screws.

#211159-PANO+-O-FP

Rev. Date: 3.15.2024

©Endura Products, Inc.

Innovation protected under patents and patents pending  
in U.S. and Canada. See [www.EnduraPatents.com](http://www.EnduraPatents.com)

## STEP 2: INSTALL STRIKE PLATES

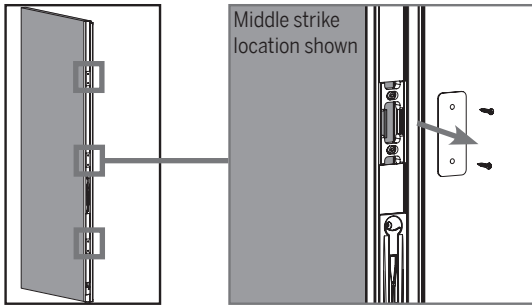

**a.** Remove the upper, middle and lower dummy strike plates.

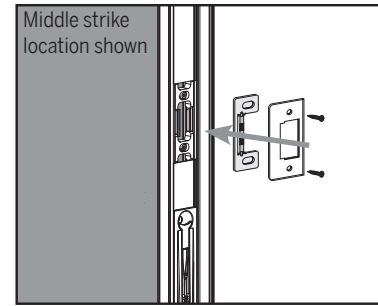

**b.** At each location install new strike plates by screwing into the retainers.

## STEP 3: CUT WEATHERSTRIP AT HEADER

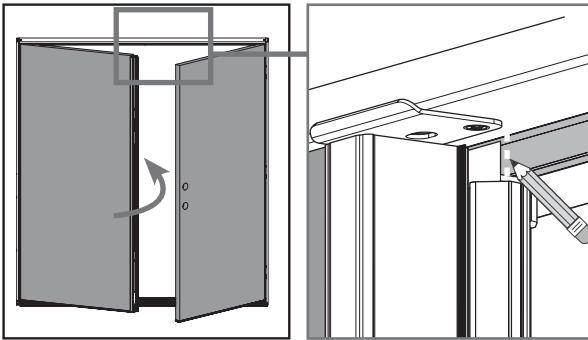

**a.** Close the inactive door. Make a mark at the location where the trim cap contacts the weatherstrip.

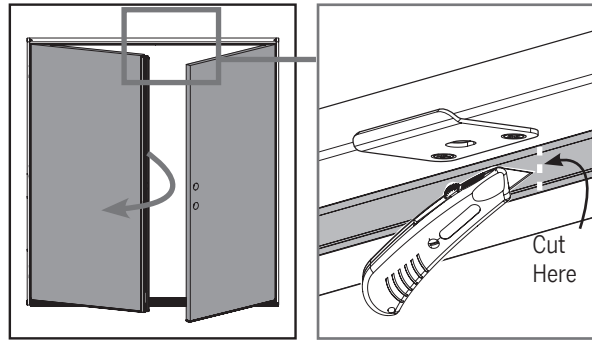

**b.** Open the inactive door. Using a utility knife, make a slit in the weatherstrip along the mark made.

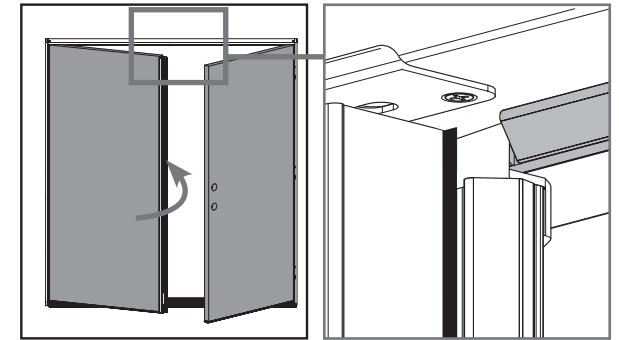

**c.** Close the inactive door panel. Ensure the weatherstrip forms a secure seal around the trim cap.

## STEP 4: CONFIRM PROPER INSTALLATION

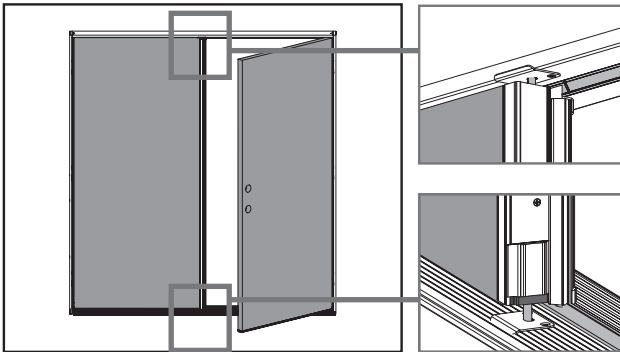

**a.** With the inactive door panel closed, engage both the upper and lower bolts to ensure they fit into the bolt receivers smoothly.

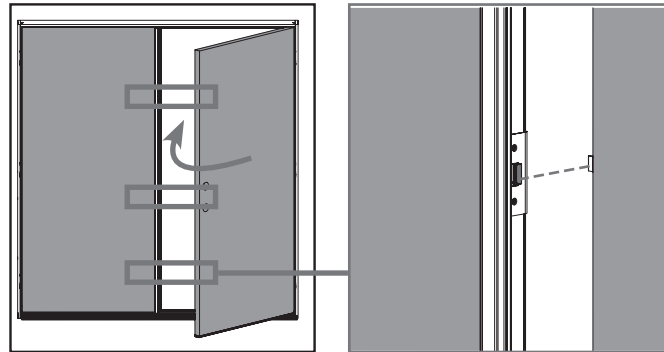

**b.** Close the active door panel and engage the lock to ensure the upper, middle and lower strike locations are properly engaged.

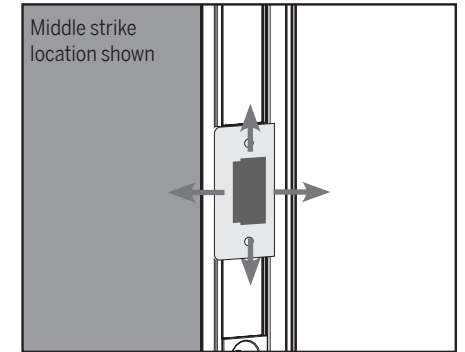

**c.** If the plates are not aligned correctly, loosen screws and slightly adjust the locations of the plates.