

Ultimate Astragal Family

Inswing to Outswing Conversion Instructions

8817 West Market Street
Colfax, NC 27235 | 800.334.2006
www.enduraproducts.com



Tools Required:

- Chop Saw
- Tape Measure
- Pencil/Marker

Kit Includes:

- Finned Trim Cap
- Outswing Short Cup
- Long Cup
- Header and Sill Strike Plates

STEP 1: REMOVE THE BOTTOM BOLT

a. For Ultimate Lite, Ultimate Slide Bolt, Ultimate Push Button and Ultimate Hurricane Astragals:

- Remove the orange securing pins from the lower bolt.
- Slide the lower bolt out of the astragal.
- Remove the corner pad, bottom pad and back pad.

NOTE: Bolts will look different depending on the type of astragal.

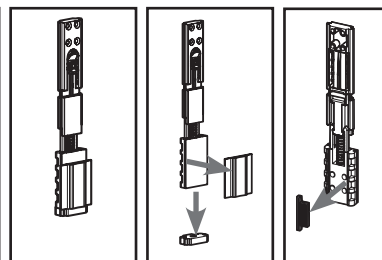
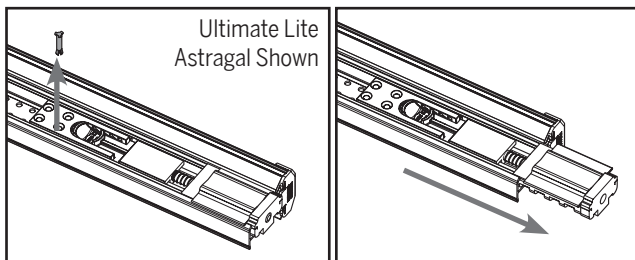
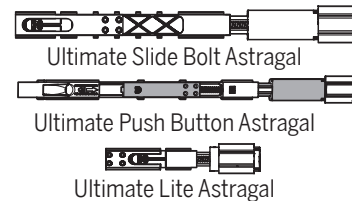

b. For Ultimate Flip Lever™ Astragal, Ultimate Trilennium™ Astragal and Ultimate Multi-Point Astragal:

- Remove any pins securing the lower bolt.
- Disengage the bolt head from the drive channels and slide the lower bolt assembly out of the astragal.
- Remove and discard the corner pad and the bottom pad.

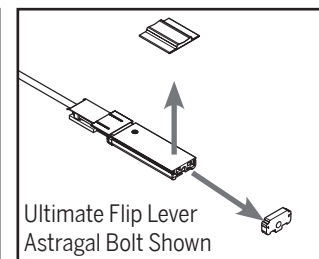
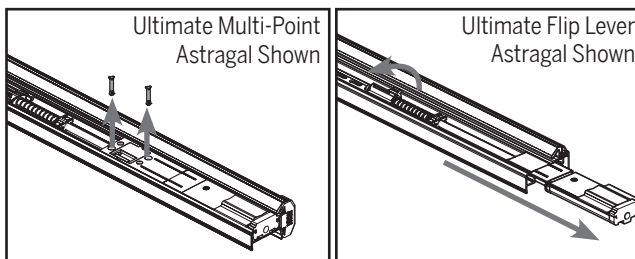

STEP 2: REMOVE THE LOWER TRIM CAP

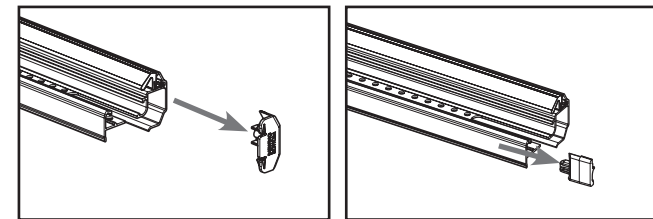

- a. Remove the lower trim cap. If present, remove the lower tail cap.

STEP 3: CUT THE ASTRAGAL BODY

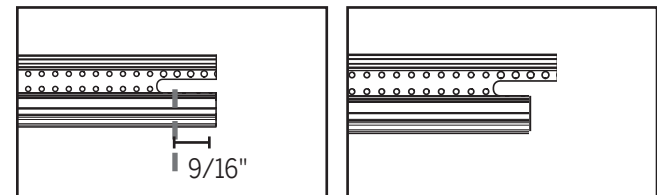

- a. If the wide and narrow sides of the astragal body are flush, cut the wide side of the astragal 9/16" using a saw. Skip this step if astragal is already cut.

NOTE: If only lower bolt sleeve was removed (Step 1b) be careful not to cut the lower bolt pin while cutting the astragal body.

STEP 4: INSTALL FINNED TRIM CAP

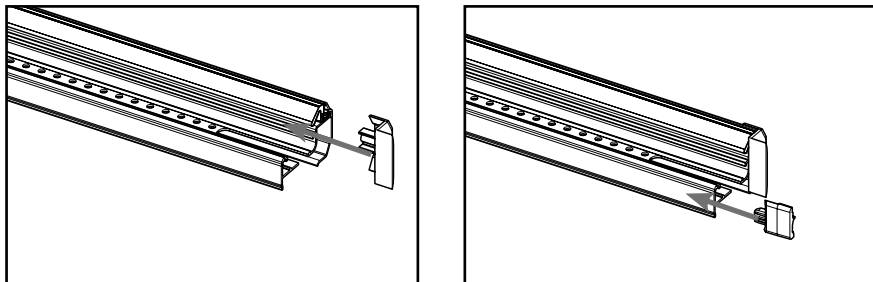

a. Install the finned trim cap on the wide side of the astragal and reinstall the tail cap removed in Step 2 on the narrow end if it was present.

STEP 5: REINSTALL LOWER BOLT/ BOLT SLEEVE

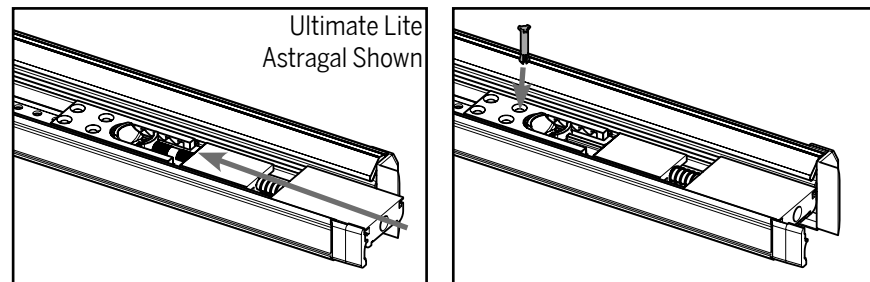

a. Return the lower bolt or the lower bolt sleeve removed in Step 1 by sliding back into the astragal. Return the orange securing pin or the screw.

STEP 6: POSITION AND INSTALL BOLT RETAINERS ON HEADER AND SILL

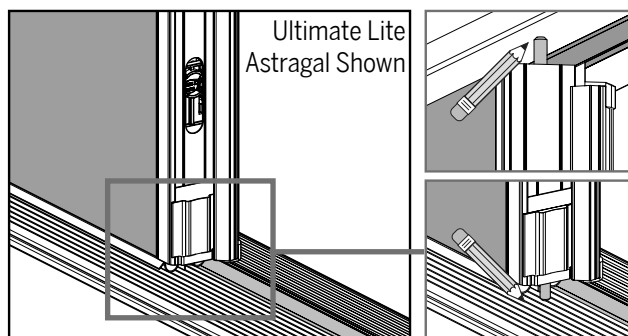

a. Press and engage the upper and lower bolts so the bolt pins come in contact with the header and the sill. Mark these points of contact.

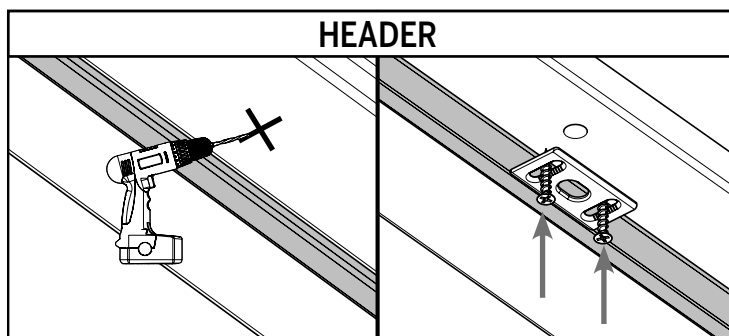

b. At the marked location on the header, drill a hole **3/8" in diameter** and at least **1-3/8" deep**. Install the upper strike plate by screwing into the header.

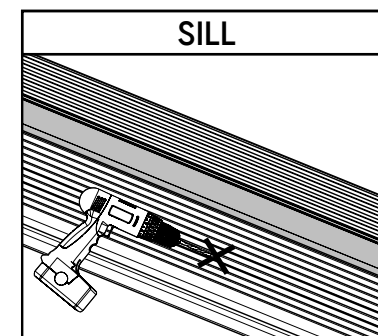

c. At the marked location on the sill, drill a hole **5/8" in diameter** and at least **1-3/8" deep**.

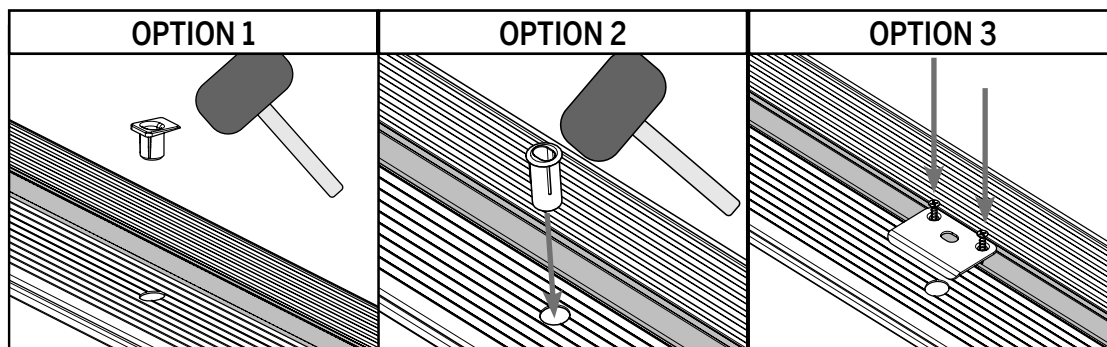

d. At the drilled location, install the sill receiver cup or sill strike plate based on the astragal type.

Option 1: Ultimate Lite, Ultimate Slide Bolt, Ultimate Push Button Astragals.

Option 2: Structural and Coastal Installations of Ultimate Lite, Ultimate Slide Bolt, Ultimate Push Button Astragals.

Option 3: Ultimate Hurricane, Ultimate Flip Lever, Ultimate Trilennium and Ultimate Multi-Point Astragals.