

ADaptive Mull Boot

Assembly Instructions



DOOR COMPONENTS MADE IN THE USA

Tools Required:

- Drill with 1/8" bit
- Miter Saw
- Caulk

Screw Pack Includes:

- (1) 1-5/8" screw
- (2) 3" screws

Note: Instructions apply for Inswing and Outswing Mull Boots. Inswing Application shown in images below

Step 1: predrill holes into sill deck.

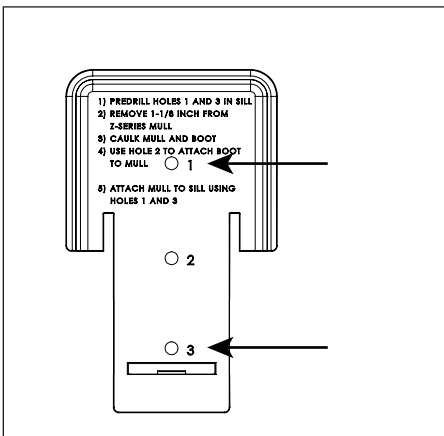

A. Locate holes #1 and #3 (labeled on the mull boot).

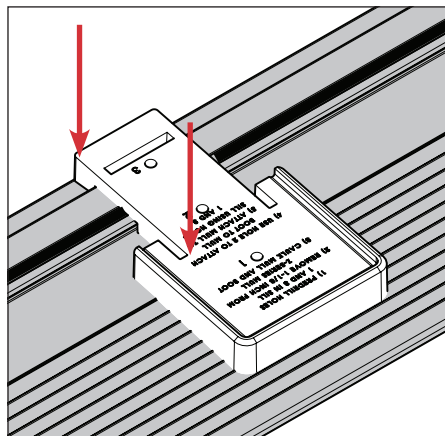

B. Place the mull boot on the sill deck to align the holes.

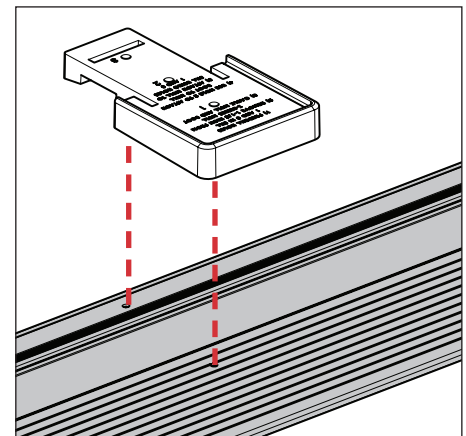

C. Drill into the #1 and #3 holes, through the sill.

Step 2: prepare and attach the mull to the mull boot.

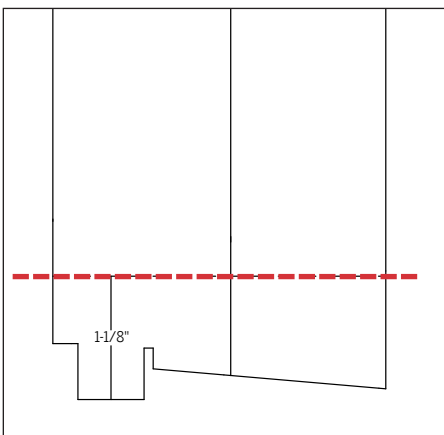

A. Cut off 1-1/8" from the bottom of a Z-Series Inswing Mull. Make sure to measure from the bottom of the lug (portion of the mull that fits into the cap channel).

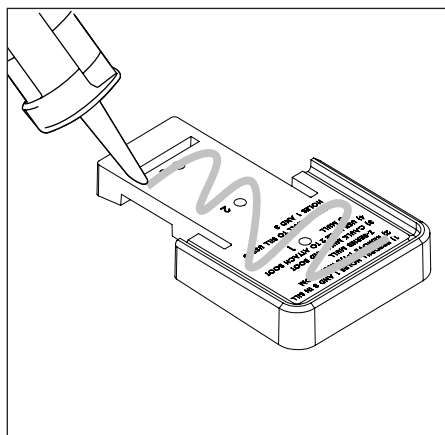

B. Apply caulk to the top of the mull boot (where the instructions are printed) and press onto the bottom of the mull.

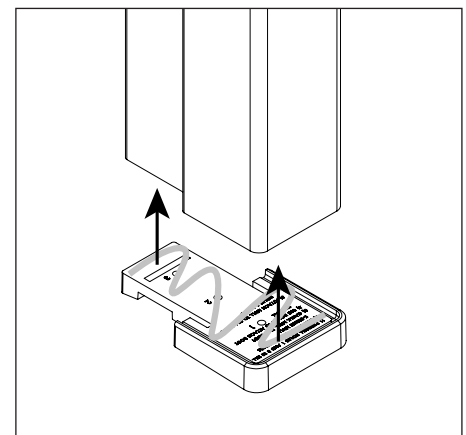

Step 2 (cont): prepare and attach the mull to the mull boot.

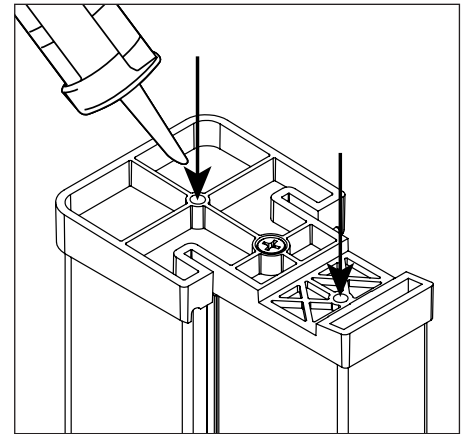
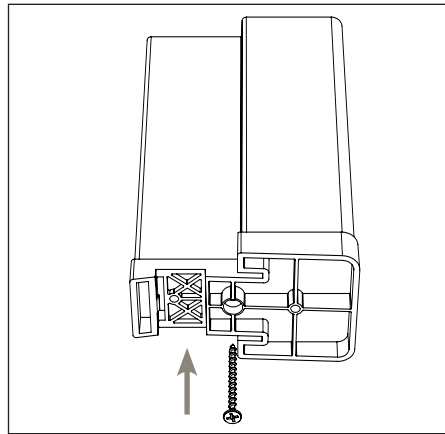
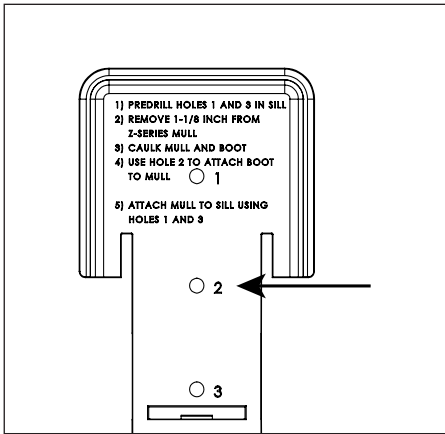

C. Attach the mull boot to the mull by fastening a 1-5/8" screw through hole #2.

D. Completely fill holes #1 and #3 with caulk.

Step 3: Attach the mull to the sill.

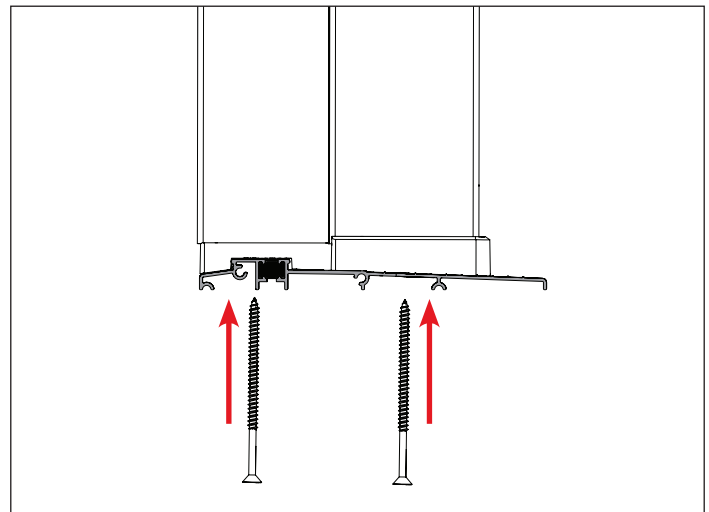
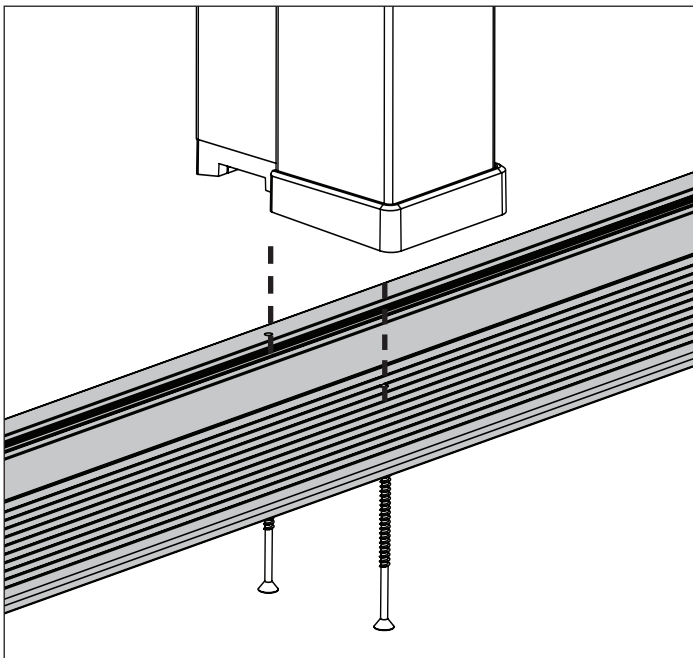

A. Attach the mull to the sill by fastening two 3" screws through predrilled holes #1 and #3 (from Step 1).