



Proven performance for your door system.

## Ultimate Astragal



Ultimate performance for french door systems. A patented three-point sealing system eliminates water and air infiltration. A unique floating boot lifts up with the flush bolt to clear the threshold when the door is opened and is secured in place when the door is closed to provide a lasting seal. Our astragals stand up to their reputation and deliver unmatched performance, standard.

*The patented floating boot delivers a perfect, secure seal, every time.*



**Why buy an Ultimate Astragal?**

No more air and water infiltration. No more leaks!

- **Patented three-point sealing system**—eliminates water and air infiltration
- **Retractable floating boot**—will not compress, become damaged or fall off after continued use. The boot lifts up with the flush bolt to clear the threshold when the door is opened and is secured in place when the door is closed to provide a lasting seal
- **4 way adjustable strike plates**—maintain even margins using existing hardware
- **Easy installation**
- **Patented performance**—engineered to be the best astragal you can buy. U.S. Patents: 5,857,291; 6,491,326 and other patents pending

**Patented Floating Boot** lifts with the flush bolt to prevent excessive rubbing and wear that lead to poor performance with traditional boot-type seals.

**Simple Solution Corner Pad** Pre-applied to every astragal, the Simple Solution ensures proper weathersealing at the weatherstrip.

**All Aluminum Body** Provides strength and encapsulates the inactive door for a secure fit.

**Flush Bolt Lock** Locks patented 24" flush bolt for additional security.

**4-Way Adjustable Strike & Deadbolt Plates** Improved alignment for better compression of the weatherstrip

**End French Door Problems** The Ultimate Astragal solves the problems builder face in french door applications.



**Floating Boot Up** Lifts with flush bolt to clear the threshold.

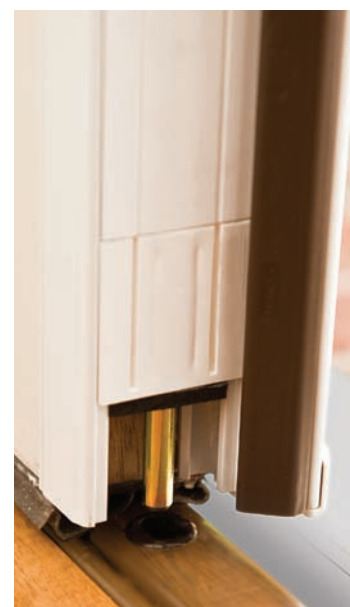

**Floating Boot Down** Secures in place when the flush bolt is lowered.



**4-Way Adjustable Strike Retainer\*** Provides improved alignment for better compression of the weatherstrip



\*Adjustable strike retainer available only on Flip Lever Upgrade and Multipoint Astragals.

**Flip-Lever Upgrade**

Adds simplicity to flush bolt engagement.

- Patent-pending
- Engages top and bottom flush bolts in one motion
- Spring-loaded floating seals tightly regardless of depth drilled for bolt
- Easy-to-use, Enhanced Accessibility



**Ultimate Astragal Veneer**

Combines the Ultimate Astragal's patented three-point system with the aesthetic appeal of real wood to match many interior finishes. Veneers are complimented by bronze end caps.

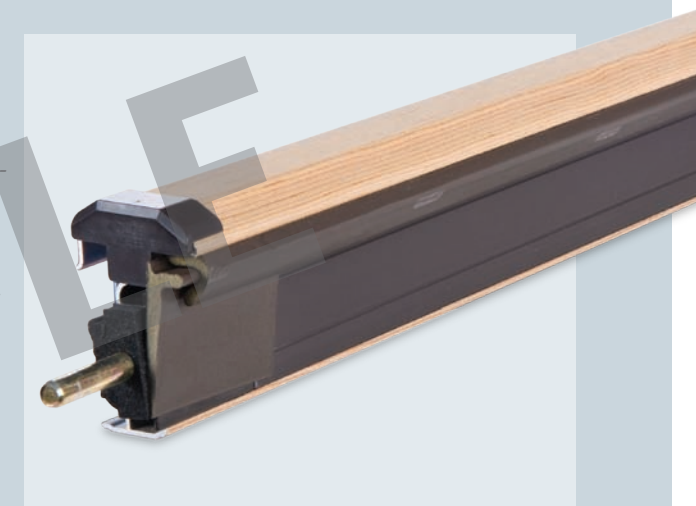

**Veneer Finishes**



**Ultimate Astragal Hurricane**

Excellent performance in high velocity wind zones without changing the appearance of the Ultimate Astragal.

- 24" Steel Reinforced Flush Bolt
- Kit includes Header Flush Bolt Retainer and Sill Flush Bolt Retainer (outswing)
- Structural Rating is available upon request

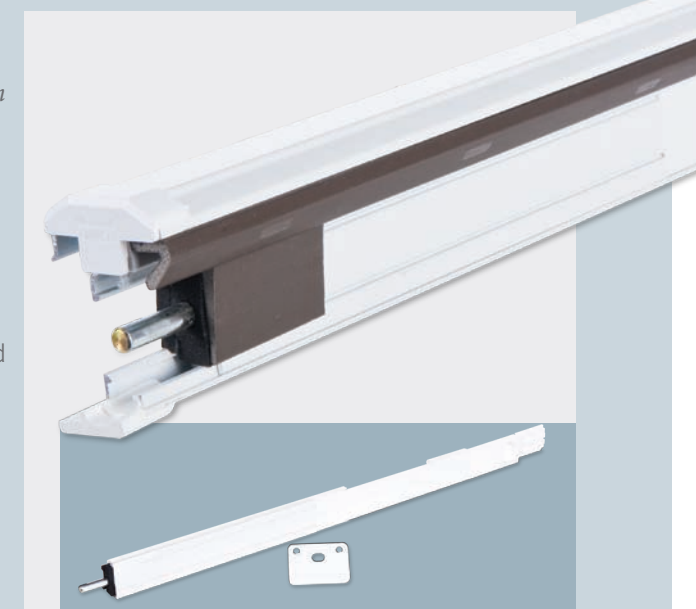

**Specifications Overview**

Features	Ultimate Astragal	Ultimate Astragal Lite	Multi-Point Astragal	Multi-Point Compatible
Patented Floating Boot	●	●	●	●
3-Point sealing system	●	●	●	●
4-way Positionable Strike & Deadbolt Plates	●	●	●	●
Simple Solution Corner Pad	●	●	●	●
PE650 Weatherstripping	●	●	●	●
Thermally Broken Aluminum Body	●	●	●	●
Flush bolt lock	●	●	○	●
24" Flush Bolt	●	○	●	●
9" Flush Bolt	○	●	○	●
Compatible for 7/8" spacing, 1-11/16" door panels	●	●	○	●

**Aluminum Body Colors**

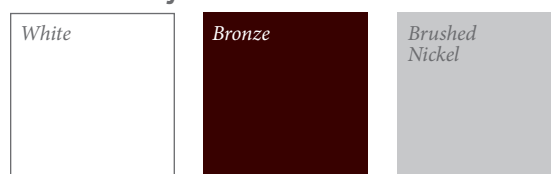

**Availability/Options**

Available for 6/8, 7/0 and 8/0 door panels	●	●	●	●
Left or Right Hand Positioning available	●	●	●	●
Available for inswing or outswing applications	●	●	●	●
Non Thermally Broken Aluminum Body	●	●	●	●
Security Flange Option for outswing doors	●	●	●	●
Flip-Lever Operation	●	○	●	○
Multi-Point Locking System	○	○	●	●
Multi-Point Compatible: W & F, Hoppe	○	○	○	●
Wood veneers: Mahogany, Oak, Pine, VG Fir, Clear Alder	●	●	●	●
Painted finishes: White, Bronze, Brushed Nickel	●	●	●	●
Structurally Rated Hurricane Astragal	●	○	○	○

**Certified Testing**

Ultimate Astragal 6/8 Inswing			Hurricane				Flip-Lever Upgrade	
Manufacturer/Brand	Panel Type	Glass Type	Water	Structural	Water	Structural	Water	Structural
JELD-WEN® Design Pro®	Fiberglass	Insert	DP20	Pend.	DP20	DP35	DP20	DP+30/-35
JELD-WEN® Energy Saver®	Steel	Insert	DP30	DP25	DP30	DP40	DP30	DP40
Masonite® Bellville® Smooth	Fiberglass	Flush	DP25	DP35	DP25	DP50	DP25	DP+45/-50
Masonite® Bellville® Smooth	Fiberglass	Insert	DP15	DP+30/-25	DP15	DP+40/-45	DP15	DP+30/-35
Masonite® Masonite® HD	Steel	Insert	DP30	DP20	DP30	Pend.	DP30	DP+40/-45
Plastpro® Select Fiberglass	Fiberglass	Flush	DP25	DP30	DP25	DP40/-45	DP25	DP+45/-50
Plastpro® Select Fiberglass	Fiberglass	Insert	DP20	DP25	DP20	DP35	DP20	DP40
Therma-Tru® Fiber-Classic®	Fiberglass	Flush	DP25	Pend.	DP25	DP+40/-45	DP25	Pend.

Ultimate Astragal 8/0 Inswing			Hurricane				Flip-Lever Upgrade	
Manufacturer/Brand	Panel Type	Glass Type	Water	Structural	Water	Structural	Water	Structural
JELD-WEN® Design Pro®	Fiberglass	Insert	LWO	DP+25/-20	LWO	DP40	LWO	DP+40/-45
JELD-WEN® Energy Saver®	Steel	Insert	DP25	DP20	DP25	DP+25/-30	DP25	DP+35/-40
Masonite® Bellville® Smooth	Fiberglass	Flush	DP25	DP+25/-20	DP25	DP35	DP25	DP+40/-45
Masonite® Bellville® Smooth	Fiberglass	Insert	LWO	DP+25/-20	LWO	DP+30/-35	LWO	DP+25/-30
Masonite® Masonite® HD	Steel	Insert	DP35	DP20	DP35	DP+20/-25	DP35	DP+25/-30
Plastpro® Select Fiberglass	Fiberglass	Flush	LWO	DP20	LWO	DP+35/-40	LWO	DP+30/-35
Plastpro® Select Fiberglass	Fiberglass	Insert	DP20	DP20	DP20	DP+40/-45	DP20	DP+40/-45
Therma-Tru® Fiber-Classic®	Fiberglass	Flush	DP20	DP+25/-20	DP20	DP+40/-45	DP20	DP+35/-40

**Other Testing**

In addition to certified testing, the Ultimate Astragal and Flip-Lever Upgrade operation and durability were successfully evaluated based on additional industry standards. These include:

Bolt Operating Lever and Bolt Durability – The bolt lever, engagement bolts, and associated mechanisms were operated for 300,000 cycles (based on BHMA A156.5, Grade 2).

Salt Spray Resistance – All components were exposed to a salt fog under elevated temperatures for 1,000 hours (per ASTM B 117).



PERFORMANCE STANDARD

8817 W. Market St., Colfax, NC 27235  
**1.800.334.2006** www.enduraproducts.com

Contact us for more information.

The information contained in this document is the confidential and proprietary information and trade secrets of Endura Products, Inc. Any disclosure, use or dissemination of such information without the express written permission of Endura Products, Inc. is strictly prohibited. Endura Products, Inc. also owns any and all intellectual property rights embodied in such information, including patent rights, copyrights, and trademark rights, and no license of any intellectual property right is intended, nor should any license be implied, as a result of the receipt of this document.