

**Ultimate Astragal Cut Down Instructions**

Revised 3 Feb 2012

NOTE – Ultimate Astragals may be shortened. Modification must be done to the top end of the astragal only.

Top End of Astragal – Upper Bolt in Locked Position (Flush with End of Astragal Body)



Bottom of Upper Bolt (Locking Knob Clears Strike Support Edge)



Upper Bolt Disengaged from Strike Support



Step 1 - Remove Upper Trim Cap, Upper Bolt, Strike Support

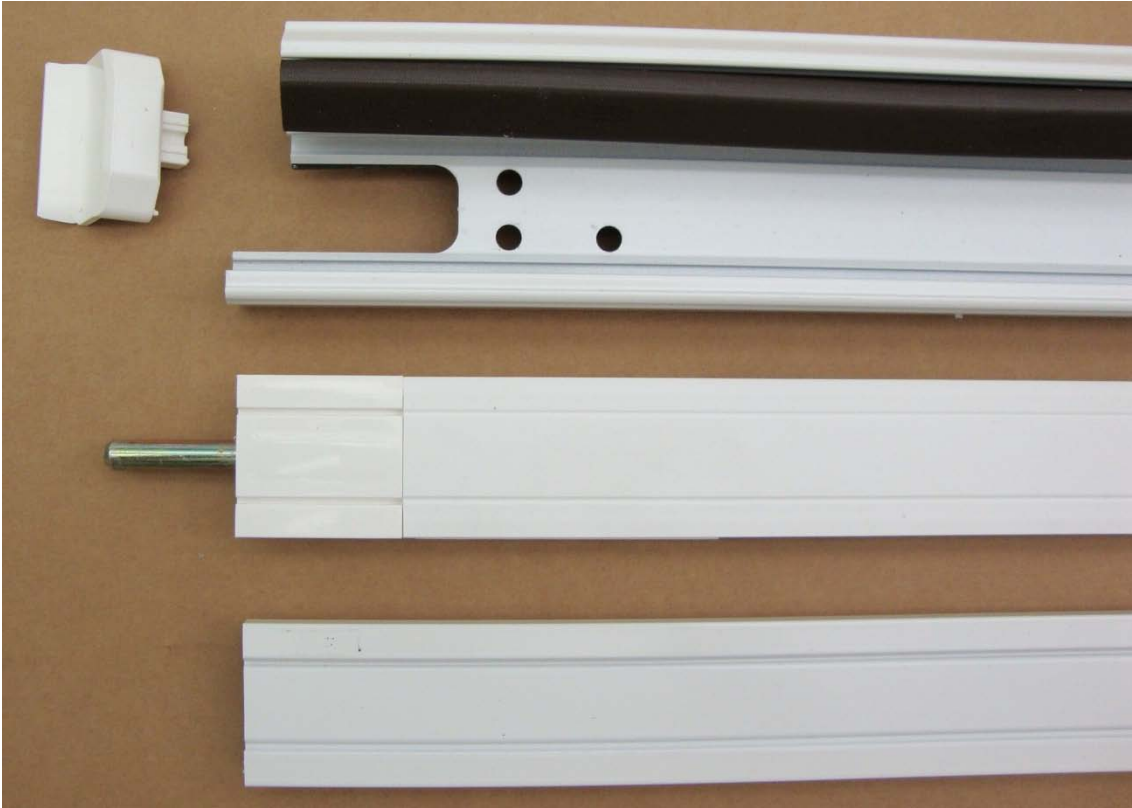

Step 2 – Cut Body to Desired Length, Measure Along Narrow Edge, Re-Cut 9/16” Notch, Re-Drill Mounting Holes

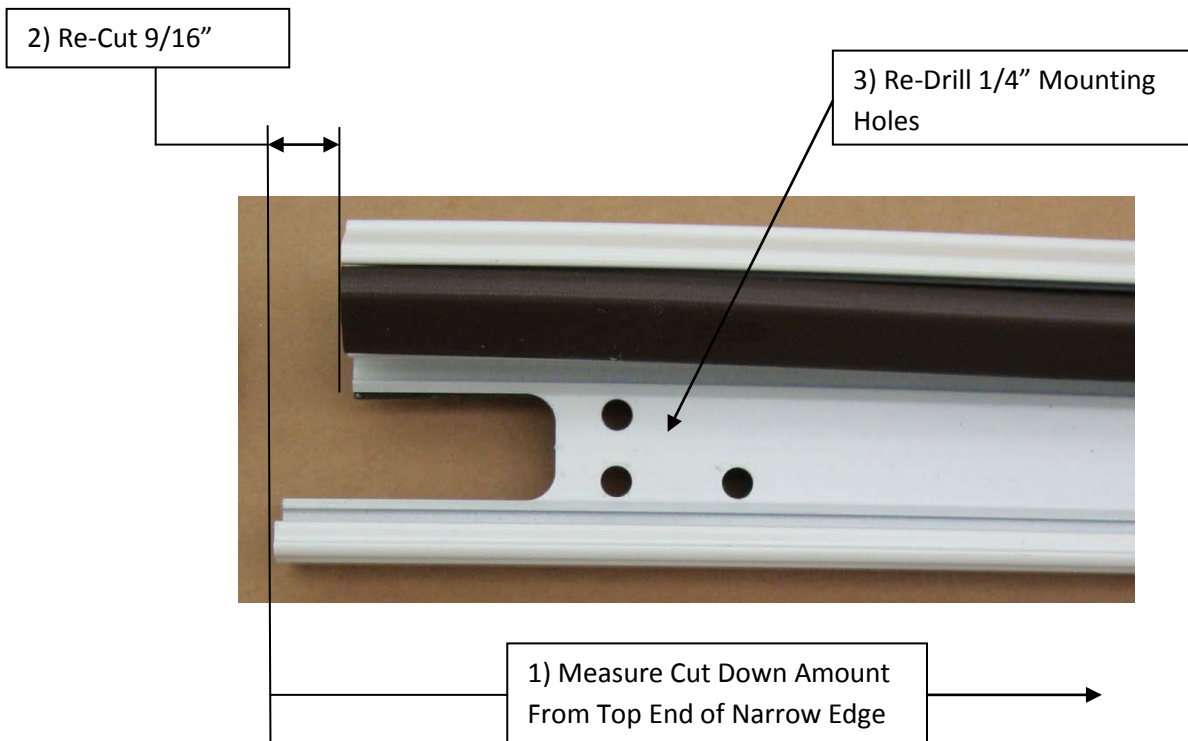

Notes

- 1) Re-cutting of 9/16" notch may require 2 cuts if the cut down amount exceeds the length of the U-shaped end groove – one cut across wide edge of astragal, then one cut length wise.
- 2) If astragal end uses two trim caps then cut down across the entire astragal body, as 9/16" notch is not required.

Step 3 – Cut Length of Strike Support by Same Amount as Astragal Body



Measure Length, Cut Down  
From Top End

Step 4 – Remove All Chips and Burrs from Cut Parts

Step 5 – Reinstall Strike Support, Top Bolt, Top Trim Cap