

### 1 Prepare Rough Opening

- Ensure the rough opening at the subfloor is:
  - free of debris
  - level and smooth

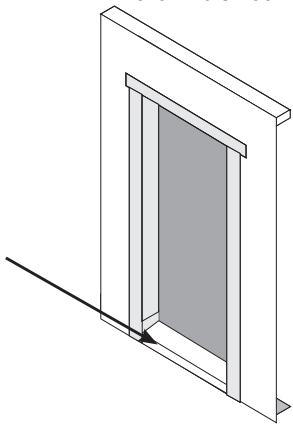

### 2 Flash Rough Opening

- Flash the rough opening according to local building codes or practices

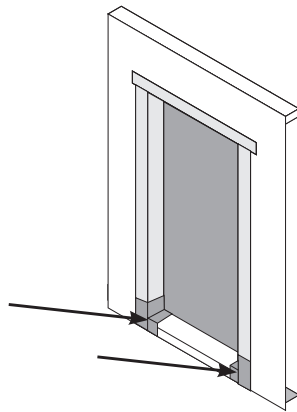

### 3a Size and Assemble SureSill™ - Openings up to 6/0 wide - This step requires one (1) channel plate

- Measure width of rough opening along the subfloor
- Cut the channel plate to 1/4" less than the rough opening width



- Dry fit end caps, then place assembly in rough opening to verify length
- Remove end caps

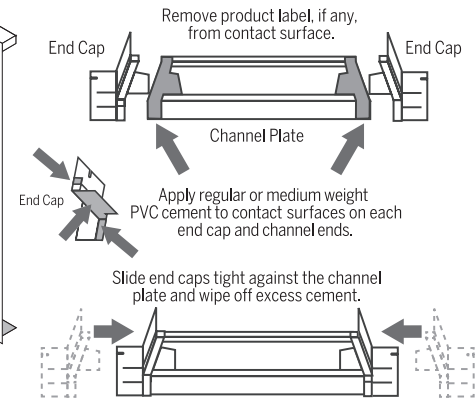

### 3b Size and Assemble SureSill™ - Openings over 6/0 wide - This step requires two (2) channel plates

- Measure width of rough opening along the subfloor
- Cut each channel plate to 1/8" less than half of the rough opening width

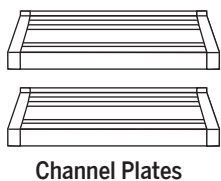

- Ensure cut ends are free of burrs

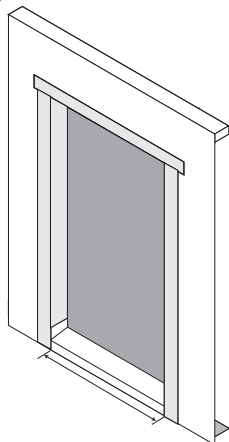

- Attach left end cap

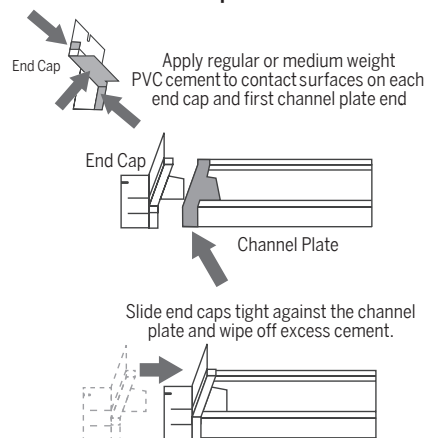

- Repeat steps for right end cap and second channel plate

- Dry fit the rigid extension coupling then place assembly in rough opening to verify length
- Apply regular or medium weight PVC cement to the top surface of the channel plate and the bottom surface of the extension coupling
- Apply over a 2" wide area
- Join extension coupling to channel plate, ensuring all slots and tabs properly mate

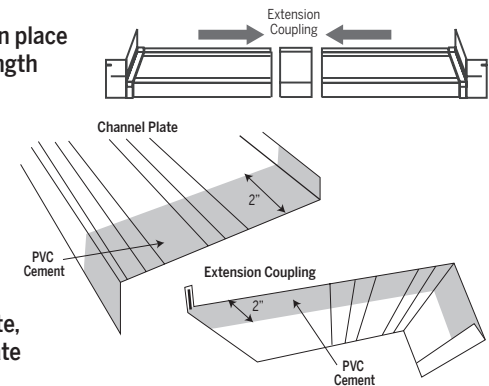

- Repeat process for other channel plate - ensure channel plate ends connect each other

### 4 Lift House Wrap

- For openings with house wrap lift wrap at each bottom corner to allow end caps to contact stud faces

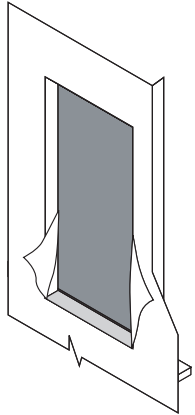

### 5 Caulk Rough Opening

Apply 1/2" wide beads of caulking as follows:

- 3 beads along bottom and 3" up each stud
- 1 bead across sheathing 1" below subfloor

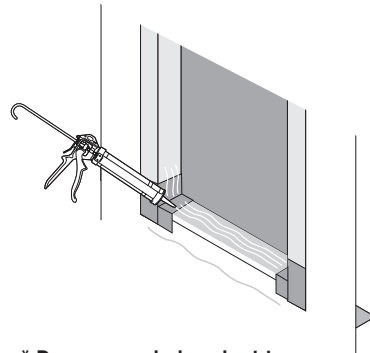

\* Recommended sealant types –  
Polyurethane, Polymer-Based or  
100% Silicone

### 6 Secure SureSill™

- Place sill pan into rough opening
- Seat tightly to subfloor and exterior sheathing
- Secure with fasteners at slots in end caps

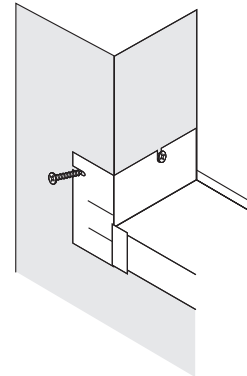

### 7 Replace House Wrap

- Return house wrap at each bottom corner to original position
- Ensure wrap overlaps end cap top edges
- Secure wrap in place

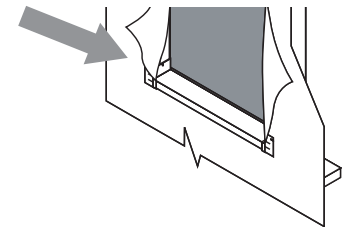

### 8 Openings Without House Wrap

- Apply self-adhering flashing along length of each stud over exterior corner
- Ensure flashing overlaps end cap top edges
- Apply flashing at header, overlapping stud flashing

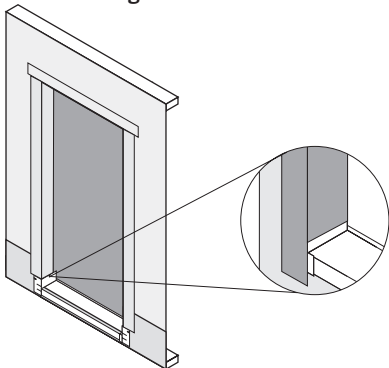

### 9 High Wind Area Sealing

On the interior side of the sill pan at each stud  
(fill in wide gaps with backer rod first)

- Caulk 6" up from bottom corner
- Caulk back edge of end cap
- Caulk along back edge of pan and sill

