

FORCE 5 DOOR SYSTEM™ OWNERS MANUAL AND WARRANTY GUIDE



Congratulations on your purchase of a certified FORCE 5 Door System™ incorporating components from Endura Products, Inc. Endura's components are designed to create performance and lasting value for your door system. This manual, and all instructions and warranties contained herein, is effective for all Force 5 Door Systems™ assembled and installed on or after January 1, 2011 for use in the United States and Canada. For additional information, contact your Force 5 dealer/distributor or refer to us at www.enduraproducts.com.



Your Force 5 Door System™: Force 5 Door Systems™ are tested and certified to air and water performance levels particular to the door panels and configurations provided by Force 5 Certified Prehangers. They incorporate the highest performance exterior door components from Endura Products, Inc. with door panels, door lites and hardware utilized by the Force 5 Prehanger, and are backed by a Performance Warranty. Please utilize this guide, in addition to instructions for door panel finishing, maintenance and warranties, for ongoing performance of your Force 5 Door System™.

Force 5 Components: Force 5 Door Systems™ include the following components:

- Z Series Composite Inswing or Bumper Outswing Sill
- Force 5 PE650 Weatherstrip
- Force 5 Simple Solution Corner Pad
- Force 5 Door Bottom
- Ultimate Astragal (French Door Units)
- Continuous Sill, One Piece Mulls and Header for Sidelite and Hinged Patio Door Units
- Endura Approved Sill Pan* (optional) **See Web site for approved pans*
- Endura or other approved Multipoint Locking System (optional)
- FrameSaver Door Frames, Mullions, Brick Mould (optional)

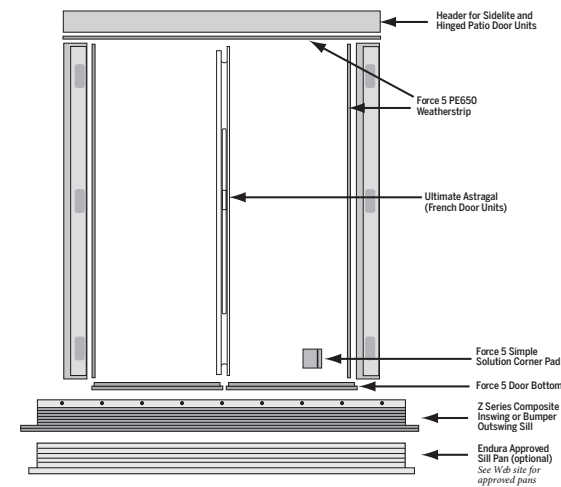

Force 5 Door Unit Identification/Registration: Effective January 1, 2011, all Force 5 Door Units can be identified by the metal Force 5 Door Tag required to be applied by the certified Force 5 Assembler. Please note the Serial Number on the Door Tag for use in registering your Force 5 Door System™ and for reporting any Warranty issues.

Force 5 Assembly and installation: Your Force 5 Door System™ was assembled and installed following specific instructions provided with the door unit. For questions regarding assembly and installation, please refer to our website: www.enduraproducts.com\Force5\AssemblyandInstallation

Force 5 Door Unit Care and Maintenance: Your Force 5 Door Unit was designed to provide the maximum possible performance against air and water infiltration for the door panel and configuration selected. For continued performance over an extended period of time, and coverage under the Force 5 Warranty, the following instructions must be followed:

Caulking and Resealing: Recaulking is required to maintain integrity of joints. At least one (1) time per year, inspect and recaulk the following with high quality exterior-grade caulk if caulk has split or is missing:

- Joints of the brickmould, frames, headers or mulls;
- Joints between the sill deck and frames and mullions
- Joints between the sill caps (active and inactive caps) and frame;
- Joints between the exterior sill and subsurface

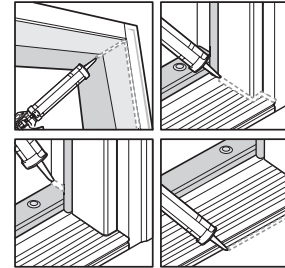

Door Sill Adjustment: Your Force 5 Door System™ incorporates an all composite Z Series sill from Endura. The following steps should be taken at least one (1) time per year to ensure proper sealing and prevention of air and water infiltration:

- As the house or door unit settles, contact between the sill and door bottom may become uneven. Adjust sill cap (inswing sills) to meet door bottom as follows:
 - Remove Simple Solution Corner Pads;
 - Remove the cap plugs on top of sill cap;
 - Adjust the screws counter-clockwise to meet the desired cap height;
 - Replace the cap plugs
 - Replace Simple Solution Corner Pads (Caulk where cap meets jamb first)

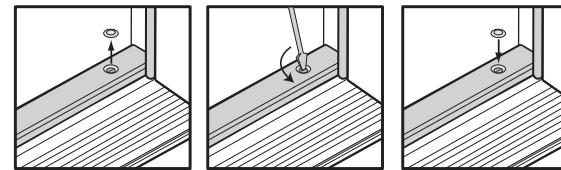

- In the case of a humped sill where adjustment of the cap will not resolve contact issues, further steps may be taken as follows:

- Remove door from hinges and opening;
- Remove brick mould or casing
- Remove hinge long screws anchoring door to rough opening;
- Shim jamb legs up to allow sill to straighten;
- Replace long screws, door, brick mould;
- Recaulk all joints

- Ensure sill cap length: In cases of extreme exposure, sill cap may not, over time, meet the overall length of the opening. Contact your Force 5 distributor or dealer for a replacement cap. Replace as follows:
 - Remove existing corner pads;
 - Remove existing cap; Using a standard slotted screwdriver, insert end of screwdriver under front (exterior) lip of cap at one end and pry upwards. Repeat step at middle and other end of cap until cap is lifted off. Remember to protect the deck of the sill with a soft cloth to prevent scratching;
 - Cut replacement cap to length of opening;
 - Position cap over cap channel and, using moderate pressure, push cap down into channel;
 - Adjust cap to meet door bottom uniformly;
 - Reapply Force 5 corner pads

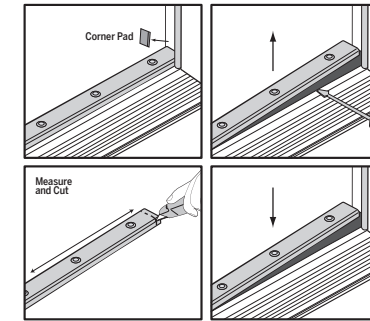
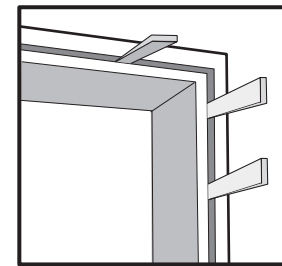

Door Bottom Wear and Replacement: Over time and operation of the door unit, door bottoms may tear, bunch or lose elasticity and memory. Door Bottoms must be checked one (1) time per year and replaced if necessary. Replacement door bottoms can be obtained from your Force 5 Distributor and replaced as follows:

- Remove door from hinges and opening;
- Remove old door bottom: Insert slotted screwdriver at one end of door bottom and remove along length of door; Clean and remove any remaining staples and caulk from bottom of door and kerfs of door;
- Cut replacement door bottom to length of door panel;
- Apply the caulk at each end of the door bottom and along the base of the exterior kerf leg;
- Press replacement door bottom in place – staple to secure;
- Allow caulk to dry and reinstall door in opening.

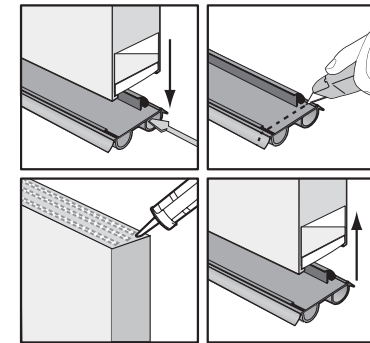

Weatherstrip Positioning, Wear and Replacement:

Force 5 PE650 Weatherstrip may be improperly installed or become torn or damaged. Check Weatherstrip upon installation and one (1) time a year for (i) tears in Weatherstrip; (ii) Weatherstrip not to length; (iii) Weatherstrip not meeting at intersection of frames and headers; or (iv) Weatherstrip bunched at bottom against door sill. Any of the above require repositioning or replacement of the weatherstrip as follows:

- Use only Force 5 PE650 Weatherstrip for replacement. Any other weatherstrip will void the Force 5 Warranty;
- Measure length of side frame/mull weatherstrip kerf from top of frame slot to sill deck – cut weatherstrip to indicated length and install in kerf. Take care to avoid bunching along length of kerf or at ends;
- Measure length of header kerf – cut weatherstrip to indicated length and install in kerf. Header weatherstrip must meet side jambs evenly at both sides.
- DO NOT PAINT WEATHERSTRIP. Paints, stains or varnishes contain solvents which, when coming into contact with materials used in weatherstripping, cause these materials to lose their flexible qualities, making them brittle and leading to a loss of sealing contact.

Weatherstrip Positioning continued

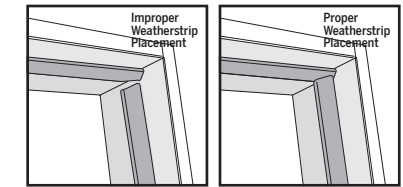

Simple Solution Corner Pad Positioning, Wear and Replacement:

Corner Pads are an integral part of the Force 5 Door System™ weathersealing. Damaged or incorrectly positioned corner pads can cause a loss of sealing. Check corner pads upon door installation and at least one (1) time a year for the following:

- Use only Force 5 Simple Solution Corner pads for installation or replacement. Use of any other corner pads will void the Force 5 Warranty.
- Corner Pads should be applied ONLY AFTER (i) final painting; and (ii) sill cap adjustment. If door frame is repainted, Corner Pads should be removed and a new pair reinstalled;
- After final sill cap adjustment (or upon replacement), position Simple Solution pad as follows:
 - Place bead of caulking at end of sill cap
 - Remove the adhesive backing pad
 - The raised fin of the corner pad should be tucked under the weatherstrip;
 - The bottom of the Simple Solution Pad should be flush with the cap of the sill;
 - Press Simple Solution Corner Pad in place

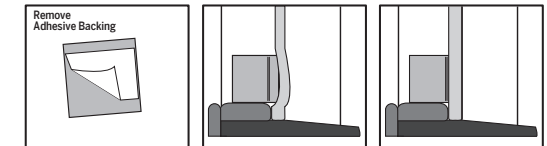

Ultimate Astragal: Endura's Ultimate Astragal is an integral part of Force 5 French Door Units. To ensure proper performance of the Ultimate Astragal, check the following upon installation and one (1) time per year:

- Ensure proper margin between active and inactive doors when active door is closed – margin should be 1/8" maximum
 - If margins exceed 1/8", remove casing, doors from hinges and long hinge screws into rough opening. Shim behind frames at hinge points on both active and inactive doors to gain proper margin.
 - Replace long screws, doors and casing. Recaulk where necessary.

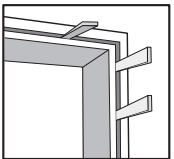
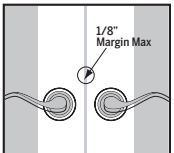

- Ensure header and sill flush bolt receivers are installed properly and flush bolt movement is for full range of operation;

- Check that depth of holes for flush bolt receivers are drilled to proper depth – 1 - 5/8" for sill receiver, through header for upper flush bolt
- Check that flush bolt receivers are installed and flush with sill cap and header surfaces
- Check that flush bolts, when fully engaged, are in full contact with sill cap and header.

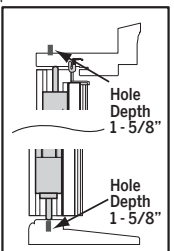

- Ensure proper compression of weatherstrip of astragal when active door is closed;
 - If compression is not tight or apparent, loosen screws on strike and deadbolt plates on astragal and reposition inward to draw active door in tighter. Retighten screws.

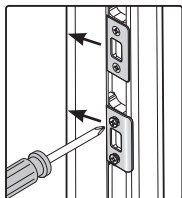

- If door unit contains Endura’s Wood Veneer Ultimate Astragal, exterior wood veneer should be finished with a stain and sealer or other finish appropriate for exterior applications. Finish must be applied to exterior wood surface initially prior to or during installation of door unit and should be checked one (1) time per year and refinished as necessary to prevent any deterioration of wood veneer.

Exterior Frame/Hardware Adjustments: Proper tight and consistent contact between the door panel and the weatherstrip is necessary for Force 5 Door System™ performance to tested standards. Check the following upon installation and two (2) times per year:

- If door panel is sagging in the frame or margins are inconsistent:
 - Ensure that one long screw is properly installed in each hinge (two on the top hinge) through the frame into the rough opening
 - Ensure that frame and door are square. Check side frames, header and sill for level and measure diagonal distances from interior header corners to opposite jamb bottom. If not level or distances are not equal, loosen long hinge screws, remove door, remove interior casing (and exterior brick mould if necessary) and reshim to obtain level and square unit. Replace long screws, door and casing and caulk all joints thoroughly

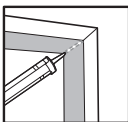
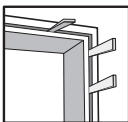
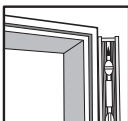

- If door panel is not meeting weatherstrip evenly or consistently when it closes:
 - Use a level to check that door is not warped. A warped door panel will need to be replaced by the dealer/distributor.
 - Check strike and deadbolt plate positioning; reposition towards the stop of the frame if required;
 - If door panel is not warped and repositioning of strike and deadbolt plates do not draw in door for full compression, check lock-side frame for alignment with panel. If frame is out of alignment, re-shim, re-adjust and re-nail frame so door meets the weatherstrip evenly from top to bottom.

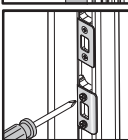
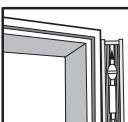

Flashing/Weatherproofing: Properly installed and maintained head flashing is required to protect the top surfaces of the door unit and prevent leaking around the door frame

- Following installation, check to ensure that sheet metal or other impervious head flashing is installed to serve as a moisture barrier above the brick mould, that a water resistant tape or seal has been installed over the head flashing, and that caulk has been applied around all joints between flashing, brick mould and other surfaces
- Visually inspect header flashing one (1) time per year for any damage, cracks in joints or other gaps in the moisture barrier. Repair or replace flashing as necessary. Recaulk all joints.

Flashing/Weatherproofing continued



Exterior Frame Painting & Refinishing: Repainting every 1 to 5 years will be required, depending upon weather exposure and the paint manufacturer’s recommendations. Any signs of blistering, peeling or cracking the finish should be immediately repaired to protect the wood underneath. Failure to properly protect the frame with a top coat will result in wood damage, including finger joint damage

- Thoroughly dry surfaces, making them free of dust, dirt, oil, grease, wax, chalk and other contaminants.
- A high quality exterior latex paint, preferably a 100% acrylic-based product, should be used as a finish coat.
- Follow the paint manufacturer’s recommendations on thinning, application techniques, re-coat and dry times.
- In general, paint should be applied when both the surface and air temperature is between 50 and 90 degrees F. Relative humidity should be below 85%.

FORCE 5 DOOR SYSTEM™ LIMITED WARRANTY

This FORCE 5 WARRANTY (“Warranty”), extended by Endura Products, Inc. (“Endura”), provides that, subject to the limitations and exclusions below, and for the duration of the applicable Warranty Period (i) the Endura Components contained therein (and as detailed in Section 1 below) will be free from non-conformities in materials and workmanship and (ii) provides for additional payment by Endura of up to a maximum of \$1,500 reimbursement if the Force 5 door system fails to perform (on the basis of water infiltration) to the certified performance criteria of that system. This Warranty applies to Force 5 certified Door Systems purchased and installed on or after December 1, 2010.

- Components Incorporated in Force 5 System this Warranty Covers:** Each Door System covered under the Force 5 Warranty shall incorporate Endura approved and supplied components reflecting those utilized in the results provided for certified testing performed by Endura for the applicable Door System. Any change in or substitution for components specified below will void the Force 5 Warranty on the Door System. Specific components supplied by Endura, utilized in Force 5 Certified Testing, and applicable to utilization in Force 5 Door Systems include:

- Composite Z Series High Dam (1 3/8”) Adjustable Inswing Door Sill or Composite Z Series High Dam Bumper Outswing Sill;
- Simple Solution Corner Pads, properly installed;
- Force 5 PE650 or other Endura tested and approved Force 5 Weatherstrip;
- Endura Force 5 Dual bulb door bottom applicable to door construction/type;
- Endura Ultimate, Ultimate 3 Point Compatible or Multipoint Astragal on double door (French) systems;
- Frame components (excluding side frames) for continuous sidelite, hinged patio and additional multiple panel configurations that meet the dimensional machining requirements and specifications as tested and provided to the Customer;
- Endura multipoint lock system or other certified tested and approved multi-point lock system (optional);
- Endura sill pan installed in accordance with published Force 5 instructions (optional)

Endura reserves the right to, and will from time to time, modify, make improvements to, substitute for or otherwise add components to Force 5 requirements based upon improvements in product and/or Force 5 Door System performance. Except as provided by Endura, wood components, including but not limited to door frames, mull posts, brick mould and mull casing are not covered by this Warranty. Other Door System components, including but not limited to door slabs (and any applied or inserted panels), hinges, glass lites, wood grilles or other hardware are not covered by this Warranty. Other Door System components, including but not limited to door slabs (and any applied or inserted panels), hinges, glass lites, wood grilles or other hardware are not covered by this Warranty.

- Force 5 Warranty Period:** Lifetime, non-transferable Warranty from the date the Force 5 Door System was purchased from an authorized dealer, except in commercial or multi-unit residential applications in which the Warranty shall be limited to 5 years from the date the Force 5 Door System was purchased from an authorized dealer and which shall be transferable during and for any balance of the original 5 year period.

- Force 5 Unit Identification:** Each Force 5 Door System may be identified by a non-removable tag or label identifying such Force 5 door unit. Removal of such label by any third party installer or residential owner will void the Force 5 Warranty on the individual Door unit.

- Force 5 Warranty Reimbursement:** If the Force 5 Door System includes all of the applicable components referenced above, has been properly assembled and installed following recommended Force 5 procedures, has not been subjected to changes in rough opening dimensions and stability (i.e. plumb and square) and has been properly maintained by the Warranty Holder, and the product (or components) fail to perform to the certified and published levels of air and water infiltration applicable to the Door System during the Warranty Period solely due to non-conformities in the product as warranted, and Endura is notified using Force 5 Warranty Claims Procedures, then Endura will:
 - Provide a factory-authorized repair or replacement component, at no cost to the Warranty Holder OR at Endura’s option, provide replacement component(s) to the Warranty Holder or Endura’s designated dealer (assembly and installation labor is not included), OR at Endura’s option, refund the Warranty Holder’s purchase price (the lesser of the original component purchase price or the original catalogue price), in lieu of repairing or replacing the components as provided; AND
 - Pay to Warranty Holder either, selected at Endura’s option, (a) the fair market value of any other property damaged due to water infiltration caused solely as a result of such nonconforming component or Force 5 Door System; or (b) Warranty Holder’s actual reasonable costs to repair or replace such damaged property or install replacement component(s) supplied by Endura as provided above, in either case, up to the maximum amount listed below for the specified Force 5 Door System. Warranty Holder must have taken reasonable steps in a timely manner to mitigate any resulting property damage, provide evidence of costs or damages incurred as requested by Endura, and timely submit a claim as provided below. If the fair market value of any damaged property is unclear, Endura may engage a third party inspector or appraiser for assistance.

FORCE 5 DOOR SYSTEM WARRANTY REIMBURSEMENT GUIDELINES				
Components Utilized	With Sill Pan ²⁾		Without Sill Pan	
	With Multipoint Lock ¹⁾	Without Multipoint	With Multipoint Lock ¹⁾	Without Multipoint
Single Door	\$500	\$350	\$275	\$200
Multiple Panel Door ³⁾	\$1,500	\$1,000	\$750	\$500
FrameSaver	Add	Add	Add	Add
Single/French Door	\$750	\$75	\$75	\$75
CSL/Hinged Patio	\$150	\$150	\$150	\$150
NAMI Certified Assembly ⁴⁾	Add \$100	Add \$100	Add \$100	Add \$100

- \$ Amount represents maximum limit on Force 5 Warranty Claims for Door units/components Referenced;
- Must be a SureSill sill pan approved by Endura and installed following Force 5 procedures;
- Must be a 3 Point Lock system tested by Endura with such door panel and approved by Endura;
- Multiple panel units include French Door, Continuous Sidelite and Hinged Patio doors;
- If the Force 5 Door System is assembled by a third party NAMI certified distributor/dealer and bears the original NAMI certified assembly label (check door-hinge edge),the Product is a “NAMI Certified Assembly”.

5.Warranty Exclusions: The Force 5 Warranty does not cover the following:

- FAILURE OF THE FORCE 5 DOOR SYSTEM DUE TO CHANGES TO OR USE OF COMPONENTS WHICH DO NOT ADHERE TO THE SPECIFICATIONS PROVIDED TO SUCH THIRD PARTIES BY ENDURA and which have not been utilized in certified Force 5 testing for such door system;
- FAILURE OF THE FORCE 5 DOOR SYSTEM DUE TO USE OF COMPONENTS WHICH ARE NOT GENUINE ENDURA COMPONENTS (as outlined in Section 1 above) and which have not been utilized in certified Force 5 testing for such door system;
- FAILURE OF THE FORCE 5 DOOR SYSTEM DUE TO IMPROPER ASSEMBLY BY THIRD PARTIES, inconsistent with recommendations and written instructions provided by Endura or generally available in Endura’s Product Manuals as amended time to time by bulletins or other written communications on Endura’s website www.enduraproducts.com;
- FAILURE OF THE FORCE 5 DOOR SYSTEM DUE TO IMPROPER INSTALLATION BY A BUILDER, REMODELER OR OTHER PERSON OR ENTITY THAT INSTALLS, OR HANDLES THE PRODUCT OTHER THAN ENDURA PRODUCTS, INC., inconsistent with recommendations and written instructions provided by Endura or generally available in Endura’s Product Manuals as amended time to time by bulletins or other written communications on Endura’s website www.enduraproducts.com;
- Failure of the Force 5 Door System due to uses or exposure to conditions for which its use and Warranty was not intended, such conditions to expressly include failure due to mechanically or other non-weather related driven water, utilization of inswing door units and components for outswing applications, further machining of or on the door panel, frame components after pre-hanging, or any other modifications or uses not specified in the Force 5 pre-hanging or installation instructions;
- Failure of the Force 5 Door System due to failure of non-Endura supplied components (i.e. door glass assembly, door panel or hardware failure).

Warranty Claims Procedures

- Homeowner notifies installer/builder/distributor rep (“Builder”) of issue. Builder inspects complaint using Job Site Pre-Inspection Checklist. Builder will make attempts to fix the problem using Force 5 Care and Maintenance instructions provided in this guide.
- If simple repairs cannot be made or have not solved the problem, Builder/ Homeowner submits Force 5 Warranty Claim Form within 60 days of original complaint;
- Builder, together with an Endura Representative (“Endura Rep”), perform a more detailed inspection to determine the cause of the complaint.
- Builder and Endura Rep determine whether the unit in question was assembled, installed and maintained in accordance with information set forth in Endura’s Force 5 Assembly, Installation and Maintenance Instructions.
- If the problem has been identified as either a field installation issue or an assembly issue, the responsible parties will cover the cost to repair the unit. Problems resulting from improper installation shall be the responsibility of the Builder; problems resulting from improper assembly shall be the responsibility of the Pre-Hanger. In the event that satisfactory repairs can not be made to the unit, the cost of replacement of the entire unit shall also be covered by the responsible party.
- If it is determined that the problem is due to a faulty door system, meaning that ALL Force 5 Assembly, Installation and Maintenance instructions were followed, Endura will then revert to the conditions stated in the written Force 5 Warranty to mitigate the problem and/or existing conditions.

Job Site Pre-Inspection Checklist

When a problem with a door unit is first identified, the Builder must field the call following the checklist below to determine the next steps:

- Ensure that the door unit in question (i) has been installed by the builder; (ii) is identified (by Force 5 tag) to be a Force 5 door unit; and (iii) contains all required Force 5 components;
- Ensure that proper installation and required Maintenance have occurred as follows:
 - Check that the door unit is square and margins are even on all sides;
 - Check that the door unit is plumb – the weatherstrip is in contact with all surface faces of the door, including top to bottom;
 - Was flashing or a drip cap installed above the door?
 - Is there caulking – without interruption – around the perimeter of the brick mould/casing and the surrounding wall?
 - Is there caulk under the sill?; Is a sill pan installed?
 - Are Simple Solution corner pads installed correctly in the bottom two corners of the door frame? Are they painted or torn?
 - Is the weatherstrip properly inserted? Meeting at the top corners? Bunched up or torn?
 - Is the lock strike plate adjusted for tight latching?
 - For French Doors (i) is the margin between the doors even and 1/8” maximum? (ii) is the hole in the sill drilled to 1 3/8” with a receiver?; (iii) is the flush bolt boot touching the cap?

Force 5 Door System Warranty Claim Form

Please photocopy and fax form to: Customer Service, Endura Products, Inc. at (336) 668-4478 or email to sales@enduraproducts.com

This Force 5 Door System Warranty Claim Form will serve as written notice to Endura Products, Inc. of failure of Force 5 System to perform to stated criteria. This form must be received by Endura within sixty (60) days of the original complaint. Upon receipt of this form, Endura will open a claim to investigate the damages listed below and determine cause. As stated in Endura’s Force 5 Warranty, Endura reserves the right to inspect, repair or replace a part or product to meet the needs of its original purpose. Endura reserves the right to mitigate any damages arising from this warranty with the original purchaser of the product to the mutual satisfaction of both parties.

Complaint Information

Name: _____
 Address _____
 Phone _____ Fax _____
 Email: _____
 Original Homeowner? Yes _____ No _____
 Dates of: Home Purchase _____
 Complaint _____
 Pre-Inspection _____

Findings _____

Description of Warranty-Related Problem and Associated Damage (attach a photo if available)

Builder and Pre-hanger Information

Builder Information
 Company: _____
 Contact _____
 Address: _____
 Phone _____ Fax _____
 Pre-Hanger Information
 Company: _____
 Contact _____
 Address: _____
 Phone _____ Fax _____